

**AMG
PNEUMATIC
ACTUATORS**

**TYPE SAD/SADT
DOUBLE-ACTING**

**TYPE SAF/SADF
SINGLE-ACTING**

AMG-PESCH®



an **ERIKS** company

QUALITY IS OUR DRIVE

AMG-PESCH®



Under the names PESCH, AMG and ABK, we are manufacturers and suppliers of complete solutions for valves, pneumatic actuators and controls.

We are active world wide, supported by a network of sales representatives and distributors, supported by our own subsidiaries and group companies.

Our activities comprise the design, manufacturing and sales of high quality pneumatic rack and pinion actuators and related control equipment. These are combined with standard valves from recognised brands or, in case of "ABK", with customised, tailor made solutions, of our own production.

The compact design, high performance valves and actuators of AMG - PESCH are specified where fluids are to be safely and efficiently transmitted in all fields of flow technology and automation.

In addition to the company headquarters in Cologne, another site is operated in Merseburg (Germany).

AMG - Pesch is supported by a reliable team of around 80 employees with a wide-range of expertise, many years of experience and Know-how, a mature and extensive product range and the latest technology in the field of flow technology and automation.

These factors have made the company one of Germany's leading providers to this industry.

The acquisition of the main assets and commercial activities of AMG-Pesch by ERIKS in 2011 will allow us to continue completing and developing our product range and to further increase customer satisfaction. Please contact us- we would be happy to provide you with more details and help in choosing your ideal combination. In addition, being part of ERIKS, we can offer you a wide range portfolio of technical products (www.eriks.com).

Quality is our drive



DOUBLE-PISTON QUARTER TURN ACTUATORS

TYPE SAD/SAF

FUNCTION TYPE SAD (DOUBLE-ACTING)

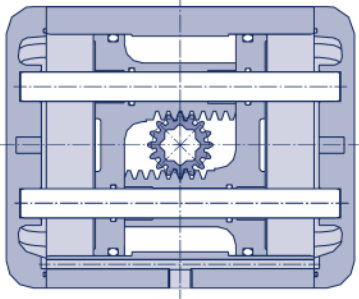

The ventilation of the external chambers via **port 4** causes a Clockwise rotation of the pinion shaft (valve closes).

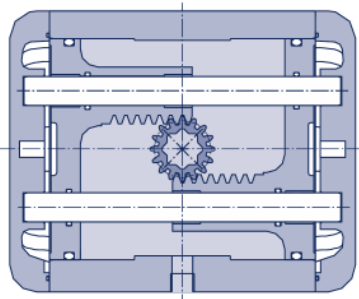

The ventilation of the internal chamber via **port 2** causes a Counter Clockwise rotation of the pinion shaft (valve opens).

Motion by compressed air

Double-acting actuators are provided with two chambers which are alternately pressurised. The generated force causes the pistons to move into opposite directions, this results in rotation of the pinion shaft which in turn operates the valve.

FUNCTION TYPE SAF (SINGLE-ACTING)

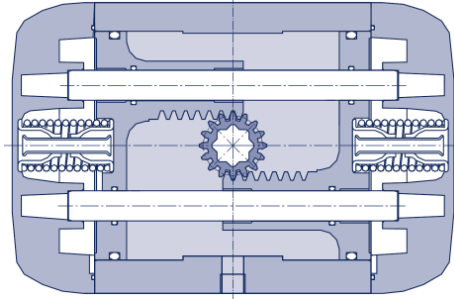

The ventilation of the internal chamber via **port 2** results in a Counter Clockwise rotation of the pinion shaft (valve opens). When venting of the interior chamber, the pinion rotates in the Clockwise (valve closes).

Motion by compressed air and spring force

When applying single-acting actuators only the internal chamber is pressurised. The generated force moves the pistons which in turn activate the valve. At the same time the encapsulated springs are loaded.

In the event of loss of air supply the compressed safety springs turn the valve into the **safety position (close or open)**.

Although the actuator types 05 and 07, as well as the SADT/SADF series are technically not identical to the SAD/SAF series, they are described here due to their comparable performance. For further information please go to our website: www.amg-pesch.com



PORT 4

PORT 2

DOUBLE-PISTON QUARTER TURN ACTUATORS

ADVANTAGES OF AMG-ACTUATORS

THE SAFE, RELIABLE AND LONG SERVICE LIFE OF AMG ACTUATORS IS GUARANTEED BY THE ROD GUIDED PISTONS:

- Tilting free motion of the pistons
- Prevents O-ring wear
- Smooth and uniform rotary motion
- Prevents stick-slip effects at low operating pressure and slow motion
- Fixed rotary angle 0° and 90°
- Precise end positions, by machined travel stops
- Unintended change of end positions during operation excluded
- 500.000 cycles guaranteed (open and close)

APPLIED REGULATIONS, APPROVALS

- ATEX acc. to guideline 2014/34/EU , Zone 1 (Gas) und 21 (Dust)
- SIL 3 acc. IEC 61508
- DIN EN ISO 5211
- VDI / VDE 3845
- DIN EN 15714 - 3

5 END CAPS

- Protected by a high grade cathodic electrodeposition coating, inside / outside, to prevent corrosion
- Spray tests acc. to DIN EN 9227 (former DIN 50021)
- Cross-cut tests acc. to DIN EN ISO 2409

FASTENERS

- Screws of high grade stainless steel
- Circlip and spacer ring stainless steel

4 SAFETY SPRING CARTRIDGES

- Captured spring cartridges, free of non-ferrous materials
- Easy and safe assembly / disassembly
- One spring is equivalent to 0,5 bar air pressure
- Corrosion protected by delta tone / delta seal coating

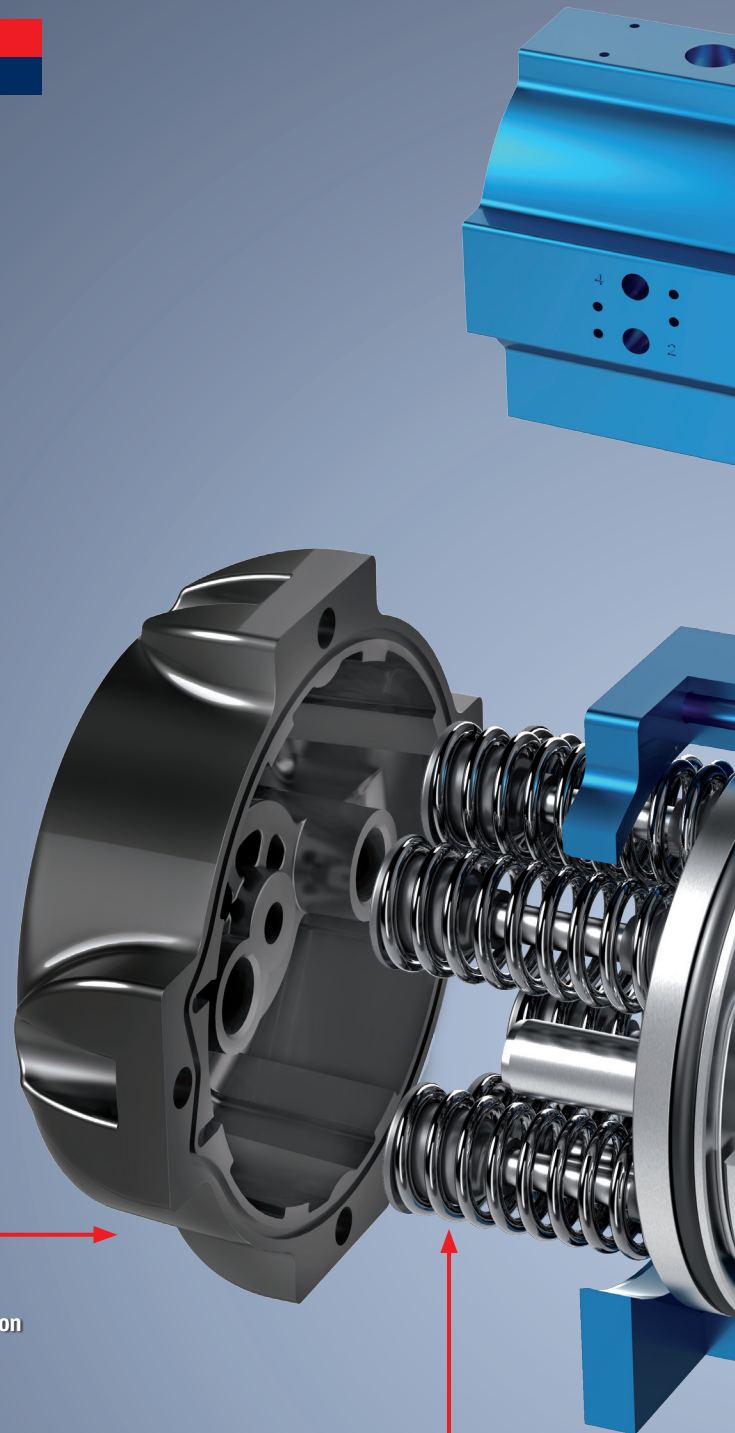

1 HOUSING

- Extruded aluminium
- Precise CNC machining
- Corrosion and wear protected by multi-layer anodising with embedded colour pigments
- Interface actuator / valve acc. to DIN EN ISO 5211
- Interface for signal transmitters and pilot valves according to VDI / VDE 3845 (NAMUR)

2 PINION SHAFT

- High strength stainless steel (1.4021)
- Corrosion resistant
- Inner square on 45° and 90° position
- High quality self lubricating shaft bearing material
- Maintenance free

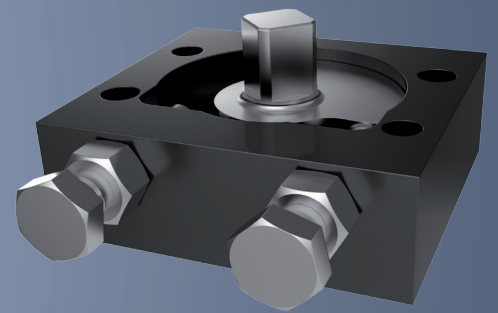
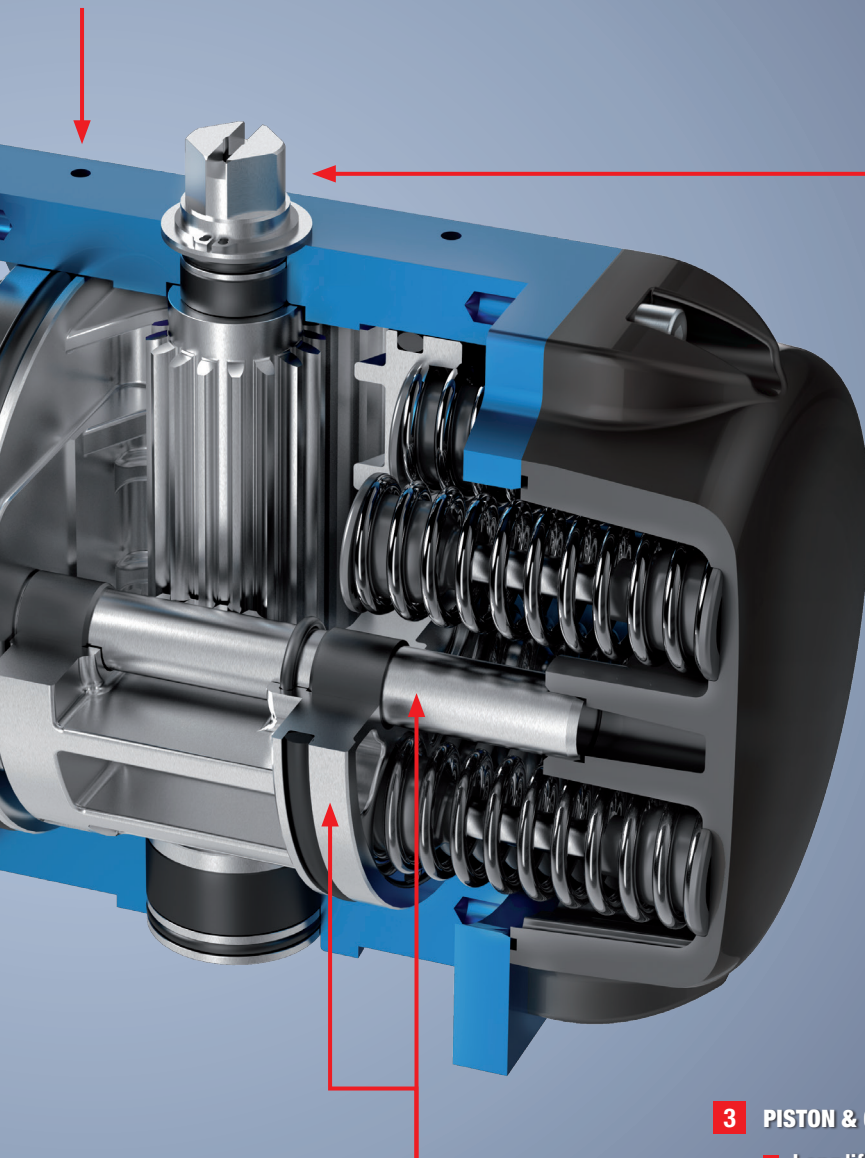
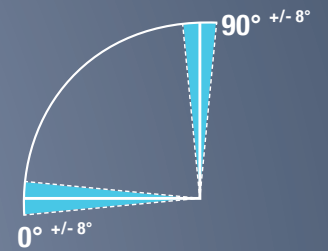

OPTION

- Adjustable travel stop module
0° +/- 8° to 90° +/- 8°
- Outside pressurised housing
- Shaft of stainless steel (1.4021 / 1.4305),
with own bearing, separately sealed
- Suitable for heavy duty applications
(high dynamic forces)

3 PISTON & GUIDE RODS

- Long life due to rod guided pistons
- Wide toothing width for high load capacity
- Maintenance free sliding bearing guides
- Machined toothing
- Machined travel stops
- Optimum piston guidance via long
and pressure resistant slide bearings
- Polished rods, made of stainless steel (1.4021)

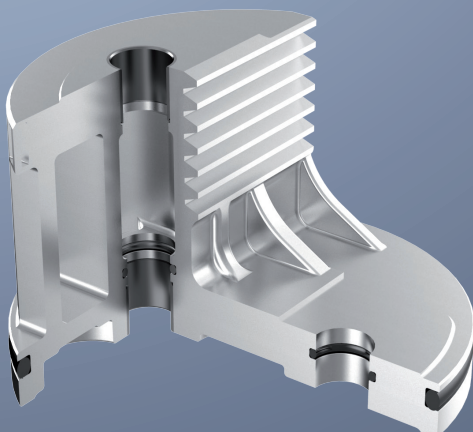

DOUBLE-PISTON QUARTER TURN ACTUATORS
TYPE SAD/SAF

PARTS LIST

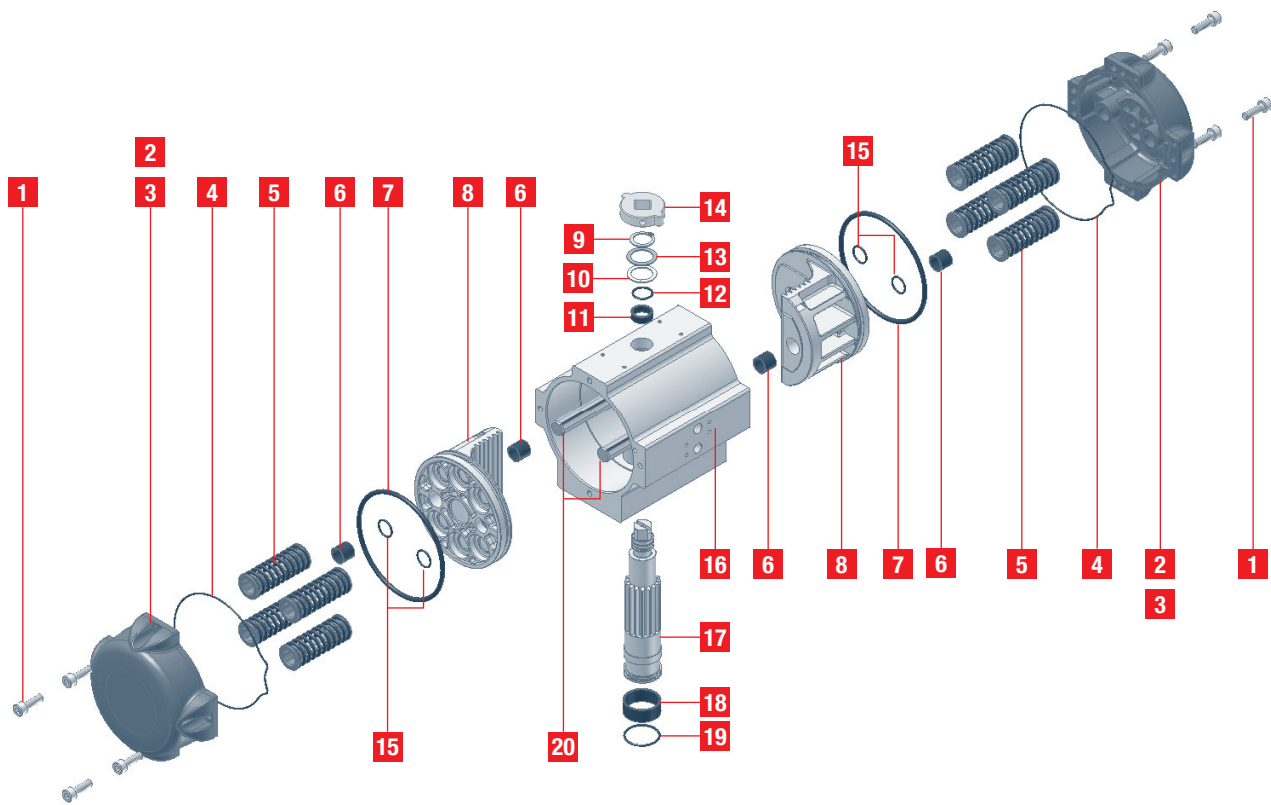

Position	Piece		Component sealing set	Designation	Material
	SAD	SAF			
1	8-12	8-12		Screw	Stainless steel
2	2			End cap (double acting)	Aluminum alloy, coated
3		2		End cap (single acting)	Aluminum alloy, coated
4	2	2	X	O-ring	NBR *
5		4-14		Safety spring package	Spring steel, coated
6	4	4		Guide bush	Bearing material
7	2	2	X	Piston sealing ring	NBR *
8	2	2		Piston	Aluminum alloy
9	1	1	X	Circlip	Stainless steel
10	1	1	X	Axial thrust bearing	Bearing material
11	1	1		Guide ring, top	Bearing material
12	1	1	X	Shaft sealing ring, top	NBR *
13	1	1	X	Spacer ring	Stainless steel
14	1	1		Position indicator	Plastic
15	4	4	X	Rod sealing ring	NBR *
16	1	1		Housing	Aluminum alloy, anodised
17	1	1		Pinion shaft	Stainless steel
18	1	1		Guide ring, bottom	Bearing material
19	1	1	X	Shaft sealing ring, bottom	NBR *
20	2	2		Guide rod	Stainless steel

This part list does not apply to the types 05,07 and the SADT/SADF series.

* alternative elastomer qualities on request

DOUBLE-PISTON QUARTER TURN ACTUATORS

TYPE SAD HIGH PERFORMANCE

HIGH PERFORMANCE ACTUATOR FOR PARTICULAR REQUIREMENTS

- Frequent operation
- Short cycle time
- High dynamic forces

CHARACTERISTICS:

- 1. Additional guide bushes
- 2. O-rings in FKM (Viton)
- 3. Additional grease depot
- 4. High precision bearing bushes
- 5. Additional guide strips
- 6. Additional bearings of guide rods in the end caps

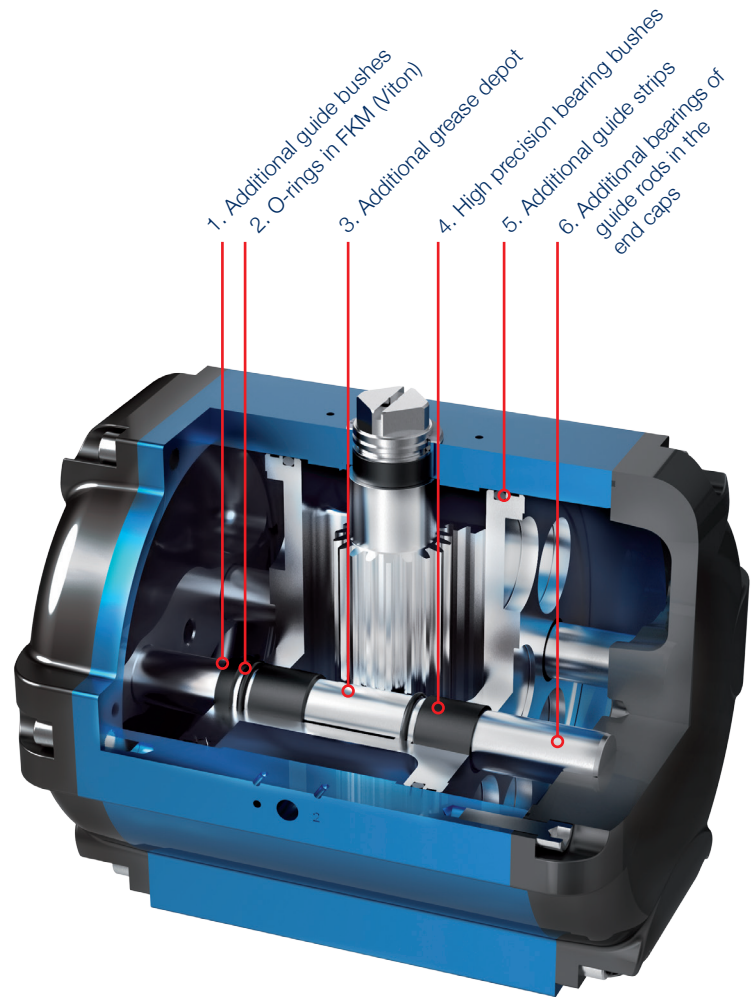

DOUBLE-PISTON QUARTER TURN ACTUATORS

TYPE SADT/SADF

DOUBLE ACTING AT 6 BAR WORKING PRESSURE

The actuators of the serie SADT / SADF achieve their high torques by tandem pistons

- SADT 45-60 8013 Nm
- SADT 50-70 14288 Nm

SPRING CLOSE AT 6 BAR WORKING PRESSURE

- SADF 45-60 2992 Nm
- SADF 50-70 5270 Nm

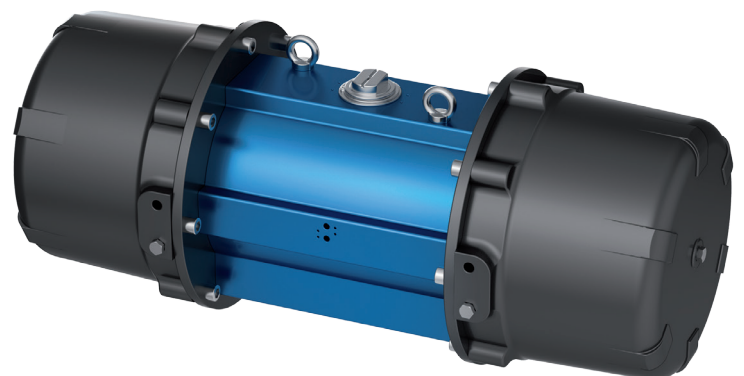

TORQUE [Nm] RATINGS OF TYPE SAD/SADT DOUBLE ACTING ACTUATORS

Type SAD/SADT	Torque M_A at air supply pressure p_e												
	2 bar	2,5 bar	3 bar	3,5 bar	4 bar	4,5 bar	5 bar	5,5 bar	6 bar	6,5 bar	7 bar	7,5 bar	8 bar
05	4,5	5,8	7,2	8,5	9,8	11,1	12,5	13,8	15,1	16,5	17,8	19,1	20,4
07	7,3	9,3	11,3	13,4	15,4	17,4	19,5	21,5	23,5	25,6	27,6	29,6	31,7
10	10	13	16	19	22	25	27	30	33	36	39	42	45
15	23	29	36	42	49	55	62	68	75	82	88	94	101
20	32	42	51	61	70	80	89	98	108	118	127	136	145
25	61	79	98	115	133	151	169	187	205	223	240	257	275
30	91	117	144	170	196	223	249	276	302	329	355	380	405
33	166	215	264	312	360	410	458	506	555	605	651	698	744
35	221	286	350	413	478	543	607	671	736	801	863	925	986
40	336	435	534	629	727	827	924	1022	1121	1220	1314	1408	1502
42	536	694	852	1005	1161	1321	1475	1631	1789	1948	2098	2248	2398
43	715	926	1136	1340	1548	1761	1967	2175	2385	2598	2798	2998	3197
45	893	1156	1419	1674	1934	2199	2457	2717	2980	3245	3495	3744	3994
50	1576	2039	2503	2952	3411	3879	4333	4792	5256	5724	6164	6604	7045
45-60	2994	3743	4491	5240	5988	6737	7485	8234	8982	-	-	-	-
50-70	4960	6200	7440	8680	9920	11160	12400	13640	14880	-	-	-	-

M_A = effective torque in Nm

TORQUE CHARACTERISTIC OF TYPE SAF/SADF DOUBLE-ACTING ACTUATORS

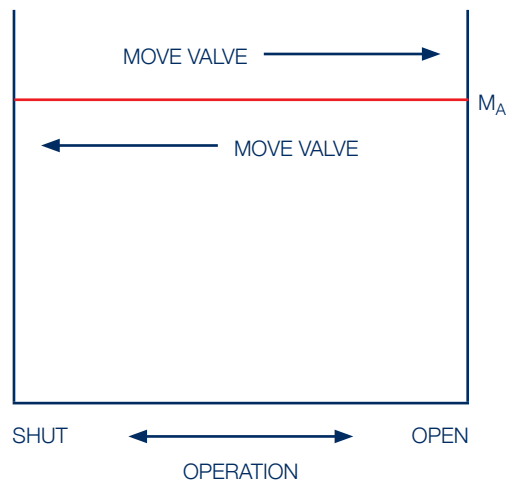

The indicated torques are constant over the complete movement

TORQUE [Nm] RATINGS OF TYPE SAF/SADF SINGLE ACTING ACTUATORS

Air supply pressure p_e	2 bar	2,5 bar	3 bar	3,5 bar	4 bar	4,5 bar	5 bar	5,5 bar	6 bar	7 bar **										
Number of springs n	4	5	6	7	8	9	10	11	12	14										
Type SAF/SADF	Spring torque $M_S \equiv$ Air torque M_A [Nm]***																			
	MIN	MAX	MIN	MAX	MIN	MAX	MIN	MAX	MIN	MAX	MIN	MAX	MIN	MAX	MIN	MAX	MIN	MAX	MIN	MAX
05*									3,6	6			4,4	7,8			5	9,5		
07*									5,2	9,5			6,4	12,0			7,8	14,5		
10	3,9	6,5	4,9	8,1	5,9	9,8	6,8	11,4	7,8	13,0	8,8	14,6	9,8	16,3	10,7	17,9	11,7	19,5	13,7	22,8
15	8,8	14,7	11,0	18,4	13,3	22,0	15,5	25,7	17,7	29,4	19,9	33,0	22,1	36,7	24,3	40,4	26,5	44,0	30,9	51,4
20	12,7	21,1	15,9	26,4	19,1	31,7	22,2	36,9	25,4	42,2	28,6	47,5	31,8	52,8	35,0	58,0	38,1	63,3	44,5	73,9
25	24,2	40,2	30,2	50,2	36,3	60,2	42,3	70,3	48,3	80,3	54,4	90,4	60,4	100,4	66,5	110,8	72,5	120,5	84,6	141
30	36	59	45	74	54	89	62	104	71	118	80	133	89	148	98	163	107	178	125	207
33	66	109	82	136	98	163	115	190	131	217	148	244	164	271	180	299	197	326	230	380
35	87	144	109	180	131	216	152	252	174	288	196	324	218	360	239	396	261	432	305	504
40	133	222	166	277	199	333	232	388	266	443	299	499	332	554	365	610	398	665	465	776
42	212	352	265	440	318	528	371	615	424	703	477	791	530	879	583	967	636	1055	742	1231
43	298	456	372	570	447	684	521	798	596	912	670	1026	744	1140	819	1254	893	1368	1042	1596
45	352	585	440	732	528	878	616	1025	705	1171	793	1317	881	1464	969	1610	1057	1756	1233	2049
50	622	1033	777	1291	933	1550	1088	1808	1244	2066	1399	2324	1555	2583	1710	2841	1866	3099	2177	3616
45-60*	880	1470	1144	1911	1408	2352	1672	2793	1936	3234	2200	3675	2464	4116	2728	4557	2992	4998	-	-
50-70*	1550	2590	2015	3367	2480	4144	2945	4921	3410	5698	3875	6475	4340	7252	4805	8029	5270	8806	-	-

* the number of springs (n) do not apply to the types 05/07 and to 45-60/50-70 either

** maximum number of springs n = 14 (special design)

*** Air and spring torque are identical at given „ p_e “ and corresponding „n“
(Detailed list of air moments can be found in the dimension sheets of the individual sizes)

Example for choosing the right actuator:

Fact: air pressure p_e 4 bar

Required: SAF with a minimim spring torque (M_S MIN) of 70 Nm

Result: SAF 30, n=8

Torques: Spring / Air min = **71 Nm** - Spring / Air max = **118 Nm**

TORQUE CHARACTERISTIC OF TYPE SAF/SADF SINGLE ACTING ACTUATORS

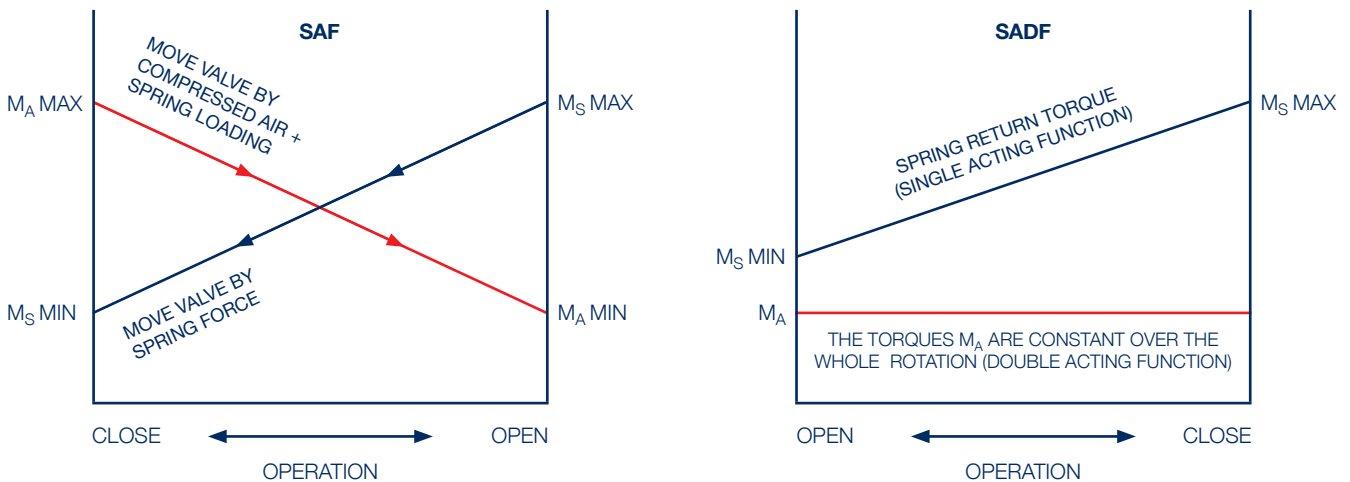

DOUBLE-PISTON QUARTER TURN ACTUATORS
TYPE SAD/SADT SAF/SADF

DIMENSION DRAWING SAD/SAF

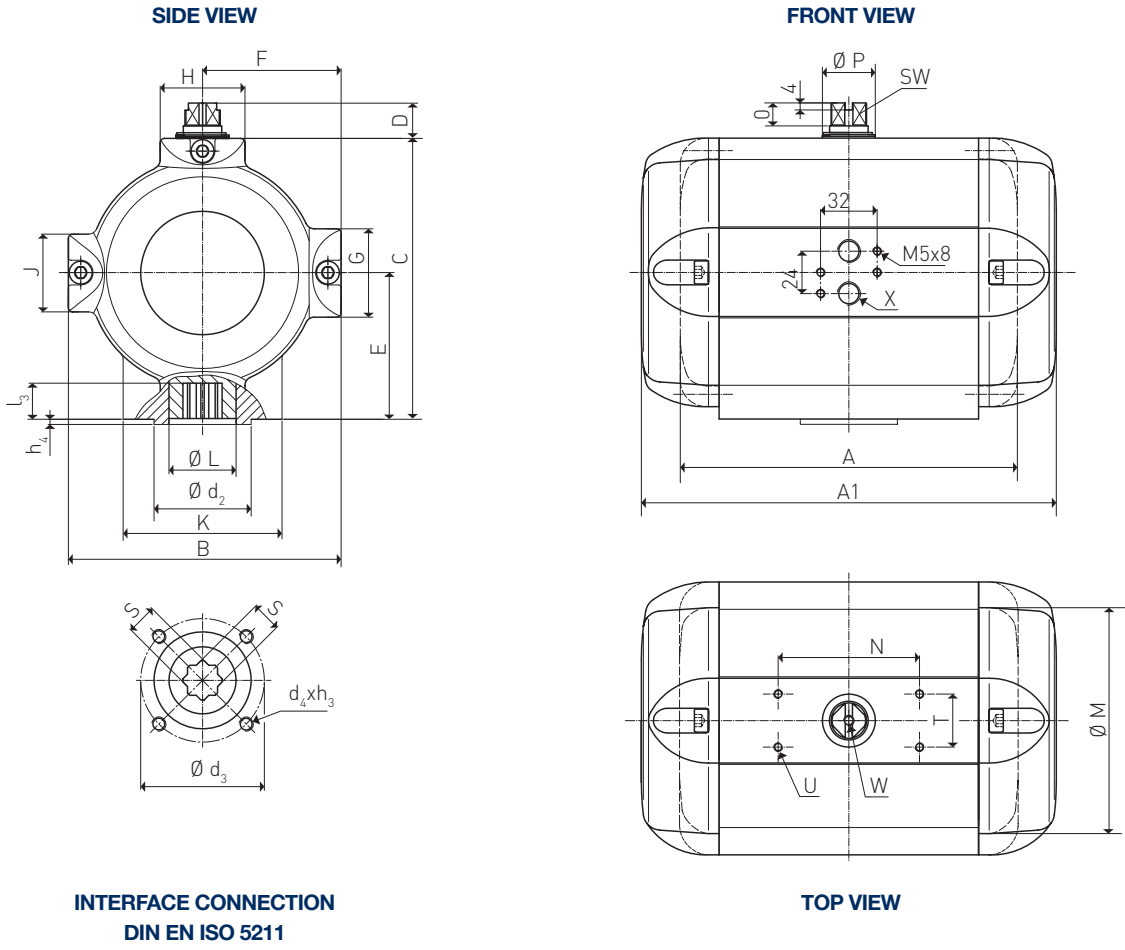

DIMENSION DRAWING SADT/SADF

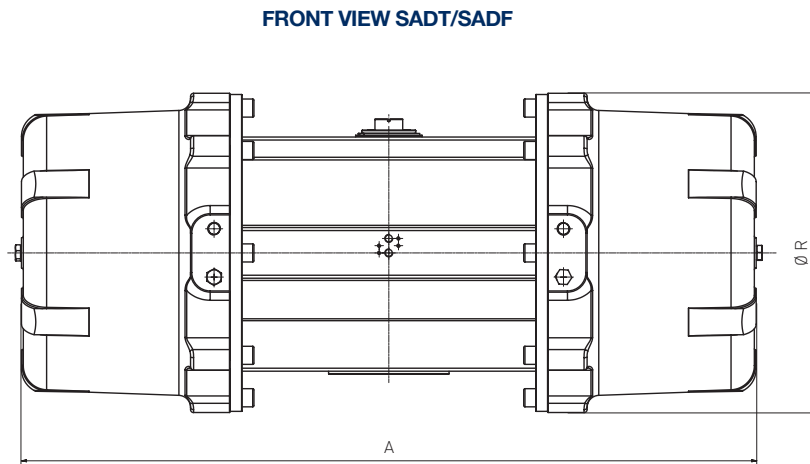

DOUBLE-PISTON QUARTER TURN ACTUATORS

TYPE SAD / SADT SAF / SADF

SIZE TABLE

Design	SAD/SAF														SADT/SADF	
	05	07	10	15	20	25	30	33	35	40	42	43	45	50	45-60	50-70
A (SAD/SADT)	84	152	138	150	175,5	191	230	253	284	318	362	463	475	567	1008	1218
A1 (SAF/SADF)	142	208	138	198	207,5	235	346	365	382	430	550	659	695	817	1008	1218
B	69	68	96	116	134	154,5	174	204	218	268	288	288	330	390	330	390
C	63	67	94,5	111	132,5	159	174	202	217	266	296	296	337	389	337	389
D	11	20	20	20	20	20	20	20	20	20	20	20	30	30	30	30
E	32	35,5	49,5	56	68,5	83	89	103	112	136	146	146	175	197	175	197
F	37	36,5	51	61	70	78,5	87	102	109	134	144	144	165	195	165	195
G	50	50	50	50	50	50	50	50	50	60	60	60	84	84	84	84
H	-	-	40	40	48	48	64	90	90	108	108	108	125	150	125	150
K	-	-	64	64	64	90	90	108	108	125	150	150	150	265	150	265
Ø L	20	28	26	28	35	38	47	56	62	62	80	106	106	132	106	132
J	-	-	44	44	44	44	50	50	50	60	60	60	84	84	84	84
Ø M	-	-	74	93	111	130	145	175	192	236	258	258	292	345	292	345
N	50	80	80	80	80	80	80	80	80	80	80	80	130	130	130	130
O	7	12	12	12	12	12	12	12	12	12	12	12	18	18	18	18
Ø P	17	22	20	22	25	30	36	45	50	50	63	63	90	110	90	110
Ø R	-	-	-	-	-	-	-	-	-	-	-	-	-	-	431	525
T	20	30	30	30	30	30	30	30	30	30	30	30	30	30	30	30
U	M4x6	M5x8	M5x8	M5x8	M5x8	M5x8	M5x8	M5x8	M5x8	M5x8	M5x8	M5x8	M5x8	M5x8	M5x8	M5x8
W	M4x8	M6x12	M6x12	M6x12	M6x12	M6x12	M6x12	M6x12	M6x12	M6x12	M6x12	M6x12	M6x12	M6x12	M6x12	M6x12
X	G1/8"	G1/8"	G1/4"	G1/4"	G1/4"	G1/4"	G1/4"	G1/4"	G1/4"	G1/4"	G1/4"	G1/2"	G1/2"	G1/2"	G1/2"	G1/2"
SW	8	12	12	12	14	17	17	22	30	30	30	30	46	46	46	46
Connection DIN 5211	F05	F03 F05	F05	F05	F07	F07	F10	F12	F12	F14	F14	F16	F16	F25	F16	F25
Ø d₂	35	-	35	35	55	55	70	85	85	100	100	130	130	200	130	200
Ø d₃	50	36/50	50	50	70	70	102	125	125	140	140	165	165	254	165	254
d₄ x h₃	M6x10	M5x8	M6x10	M6x10	M8x13	M8x13	M10x16	M12x20	M12x20	M16x25	M16x25	M20x32	M20x32	M16x25	M20x32	M16x25
Number of screws	4	4	4	4	4	4	4	4	4	4	4	4	4	8	4	8
h₄	3	-	3	3	3	3	3	3	3	4	4	5	5	5	5	5
l₃	12,5	16	16	16	20	20	25	30	30	40	40	50	50	60	50	60
s	11	14	14	14	17	17	22	27	27	36	36	46	46	55	46	55

WEIGHTS – STROKE VOLUME – OPERATING TIMES

Size	05	07	10	15	20	25	30	33	35	40	42	43	45	50	45-60	50-70
Weight [kg]																
Type SAD/SADT	0,7	1,1	1,8	2,8	4,0	6,0	12,0	13,5	18,5	24,0	34,0	58,0	75,0	126	155	265
Type SAF/SADF	0,9	1,3	1,9	3,5	5,0	8,5	13,5	18,5	26,0	37,5	48,5	78,0	102	170	190	320
Stroke volume [dm³]																
Type SAD/SADT	0,05	0,2	0,3	0,7	1,0	2,0	2,8	5,1	6,8	10,6	16,4	20,5	25,6	43,8	94,6	150
Type SAF/SADF	0,05	0,1	0,2	0,4	0,5	1,0	1,5	3,0	3,9	6,1	9,5	11,5	14,7	25,0	30,5	54
Operating times [sec]*																
Type SAD/SADT OP.	0,1	0,1	0,1	0,2	0,4	0,4	0,5	0,8	1,0	1,5	2,5	3,3	4,0	7,0	35	45
Type SAD/SADT CL.	0,1	0,1	0,1	0,2	0,4	0,4	0,5	0,8	1,0	1,5	2,5	3,3	4,0	7,0	45	55
Type SAF/SADF** OP.	0,1	0,1	0,1	0,2	0,4	0,4	0,5	1,0	2,0	3,0	5,0	6,0	7,0	11,0	20	30
Type SAF/SADF** CL.	0,1	0,1	0,1	0,1	0,2	0,2	0,3	0,5	1,0	1,5	2,0	2,0	3,0	4,0	25	35

* Operating times at 4,5 bar air pressure supply and without load (standard values, OP. = Open / CL. = Close).

** Type SAF with 9 springs

DOUBLE-PISTON QUARTER TURN ACTUATORS
TYPE SAD/SADT SAF/SAF

DIMENSION DRAWING SAD/SAF BR03C

SIDE VIEW

FRONT VIEW

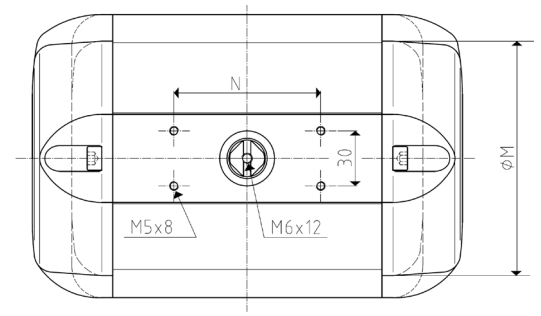
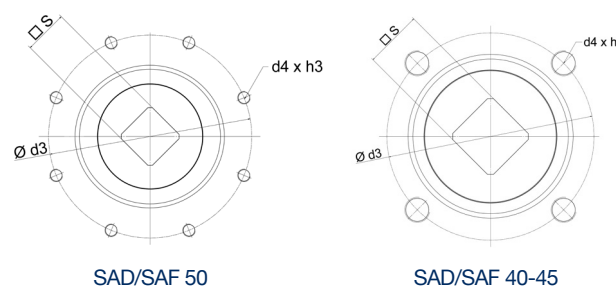
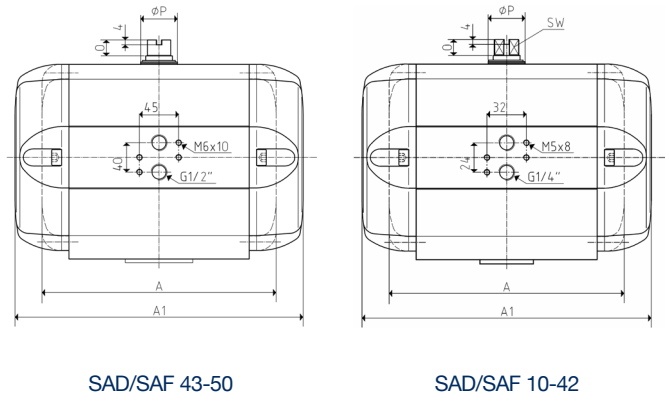
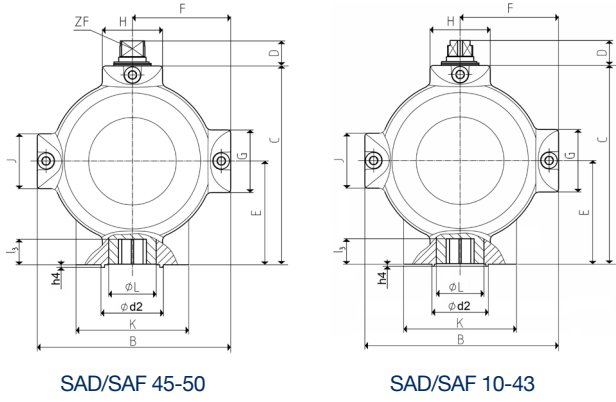

INTERFACE CONNECTION DIN EN ISO 5211

TOP VIEW

The dimensions and deviating technical data for SAD / SAD BR03 can be found in the datasheets.

DOUBLE-PISTON QUARTER TURN ACTUATORS

TYPE SAD / SADT SAF / SADP

DIMENSION DRAWING SAD/SAF BR16

SIDE VIEW

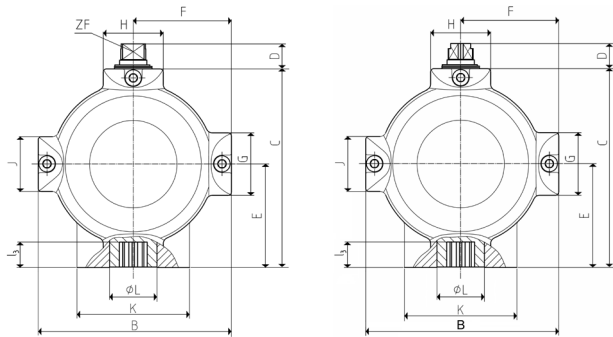

SAD/SAF 45-50

SAD/SAF 10-43

FRONT VIEW

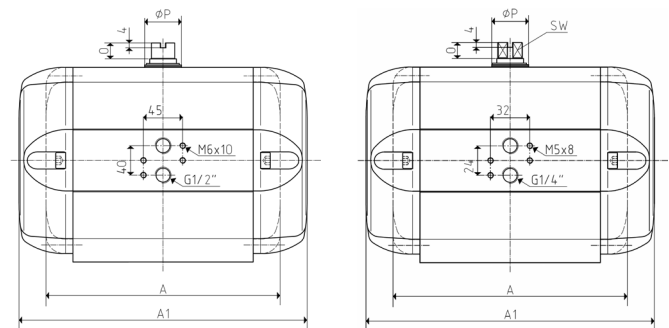

SAD/SAF 43-50

SAD/SAF 10-42

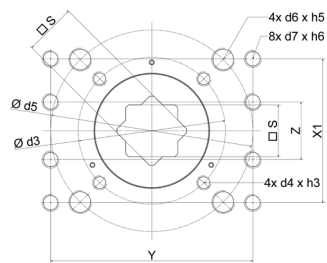

SAD/SAF 40-42

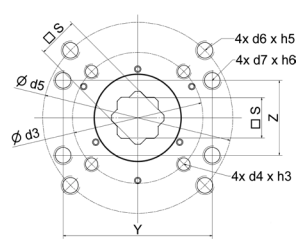

SAD/SAF 10-35

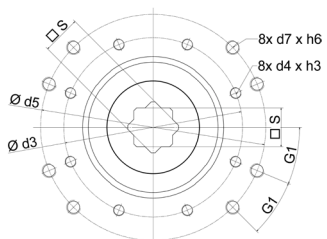

SAD/SAF 50

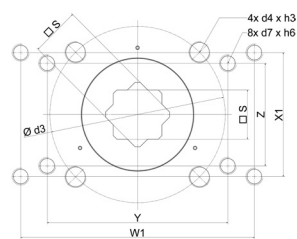

SAD/SAF 43-45

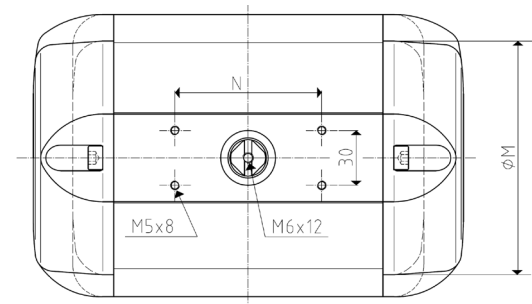

TOP VIEW

INTERFACE CONNECTION DIN EN ISO 5211

The dimensions and deviating technical data for SAD / SAD BR16 can be found in the datasheets.

DOUBLE-PISTON QUARTER TURN ACTUATORS

TYPE SAD/SAF

TYPE OF DESIGN, TECHNICAL DATA

APPLIED STANDARDS

- In accordance with the practicable standards, for example DIN EN ISO 5211, DIN EN 15714 - 3, VDI / VDE 3845

MAINTENANCE

AMG ACTUATORS ARE FREE OF MAINTENANCE

Provided that:

- The actuator is properly mounted
- The operating medium used is clean and non-aggressive
- The actuator is operated under normal ambient conditions
- Usage according to regulations

OPTIONS

- Extended angle of rotation 120°, 135°, 180°, 270°
- Adjustable inner / outer travel stops +/-8°
- Ambient temperature up to +100°C
- Ambient temperature down to -60°C
- Sealing elements made of FKM (Viton) or alternatively fluorosilicone
- Tailor made mounting kits and dimensioning acc. to customer requirements
- Variable cycle times (fast / slow)
- Variable sens of rotation (clockwise / counterclockwise)
- Coating options:
 - HARD-COAT
 - Chemical nickelpating
 - Plastic-coating
 - Silicone-free lacquer
 - Special lacquer
- Special housing : stainless steel

DESIGN

- Pneumatic double-piston quarter turn actuator

DESIGN FEATURES

- Rack-and-pinion system, piston guidance via guide rods (exception type 05, 07)

DEGREE OF ROTATION

- 90°

PRESSURE RANGE

- SAD/SAF series: min. 2 bar, max. 10 bar
- SADT/SADF series: min. 2 bar, max. 6 bar

OPERATING MEDIUM

- Dry and filtered compressed air.
- Other, non-aggressive gaseous media upon request

AMBIENT TEMPERATURE

- -25°C to +80°C

MOUNTING POSITION

- Any

RESISTANCE TO CORROSION

- Industrial atmosphere

LUBRICATION

- Permanent lubrication with grease ISO 51825-K2K-30

WERKSTOFFE

- Housing Aluminum alloy, anodised
- End cap Aluminum alloy, coated
- Piston Aluminum alloy
- Piston bearing Bearing material
- Guide rods Stainless steel
- Pinion shaft Stainless steel
- Pinion shaft bearing Bearing material
- Safety springs VD Si Cr, delta tone / delta seal coating
- Sealings O-ring, NBR, 70 shore

TORQUES

- From 3,6 Nm (SAF 05) to 14880 Nm (SADT 50 / 70) (see torque charts)

DOUBLE-PISTON QUARTER TURN ACTUATORS

TYPE SAD/SAF

CONNECTING OPTIONS FOR ACCESSORIES

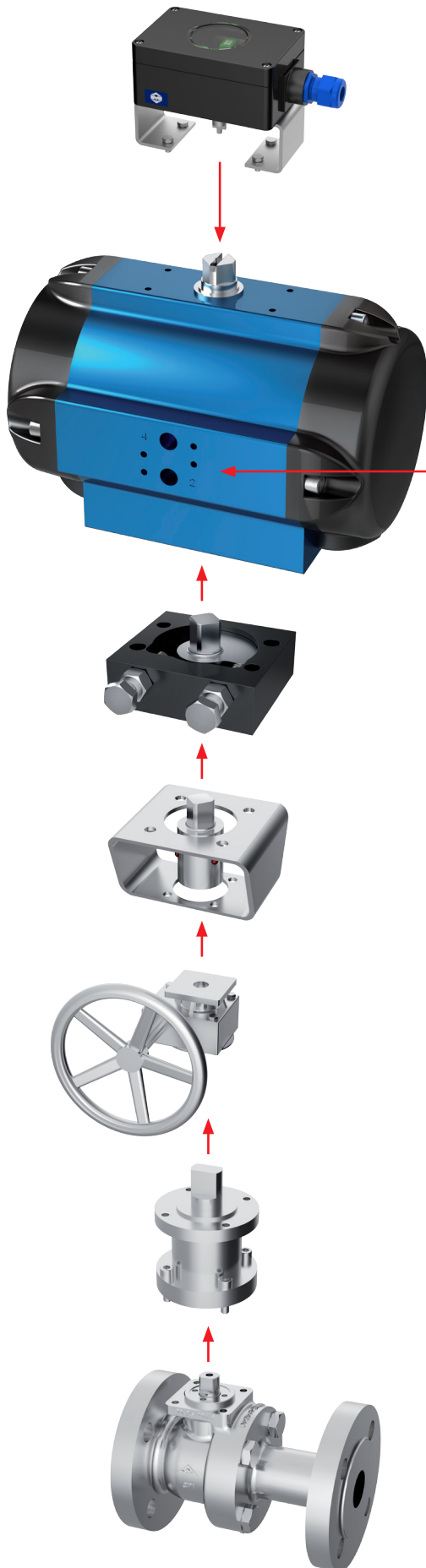

LIMIT SWITCH BOX

for signaling of end position

SOLENOID VALVE

for quarter turn actuator control

TRAVEL STOP MODULE

Adjustable travel stop module

0°+/-8° bzw. 90°+/-8°

COUPLING & BRACKET

to connect valve and actuator

MANUAL EMERGENCY GEAR

for manual operation of the actuator

PINION SHAFT EXTENSION

to keep away extreme process temperatures from the actuator, to implement a leaking advice, monitoring of functionality and tightness

VALVES

all designs featuring a rotary movement, such as

- Ball valves
- Plug valves
- Butterfly valves
- Control valves

DOUBLE-PISTON QUARTER TURN ACTUATORS

TYPE SAD/SAF

PRODUCT RANGE

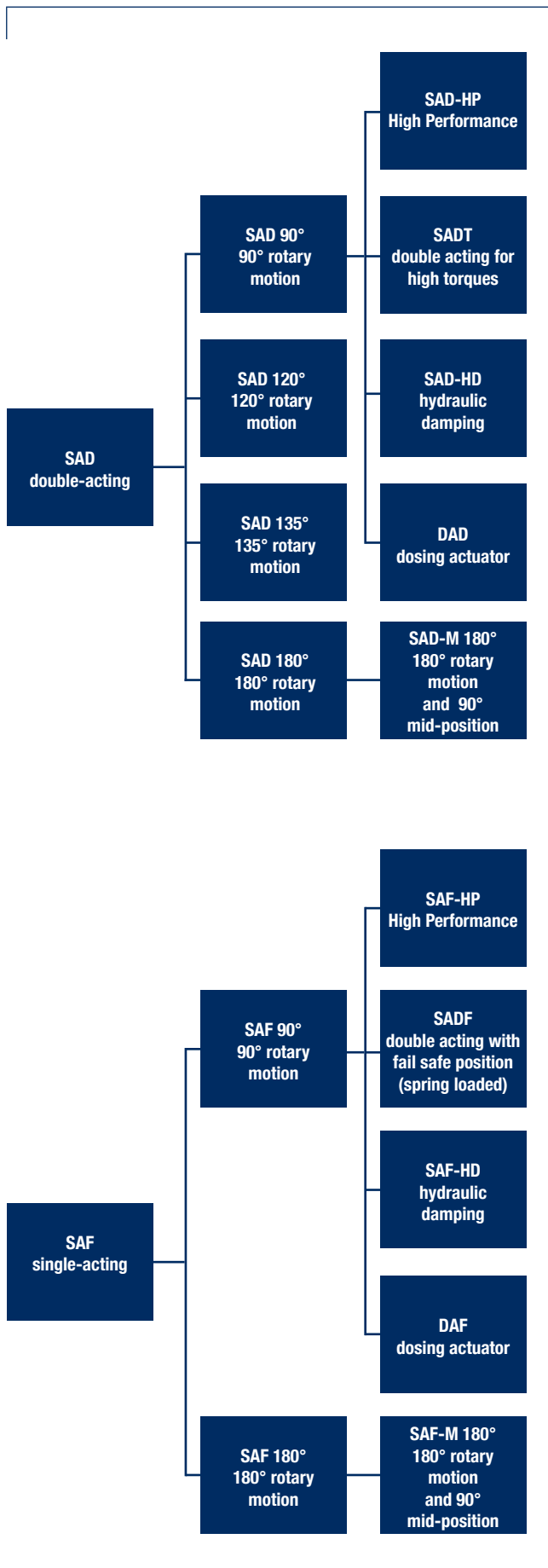

SERVICE AND QUALITY MANAGEMENT

SERVICE

- Consulting, performance of training courses
- Assembly and setting-up
- Testing and approval of valves, actuators and complete units according to customer requirements and important international regulations
- After sales and spare parts service
- Repair and overhaul

QUALITY MANAGEMENT

Quality Management System according to DIN EN ISO 9001, audited by TÜV-Rheinland Cert GmbH

This brochure presents our actuator series SAD/SAF/SADT/SADF. For more information about our others series, please visit our homepage www.amg-pesch.com or take directly contact with our sales department.

AMG actuators overview

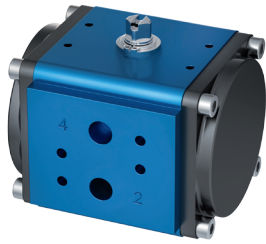

SAD 05

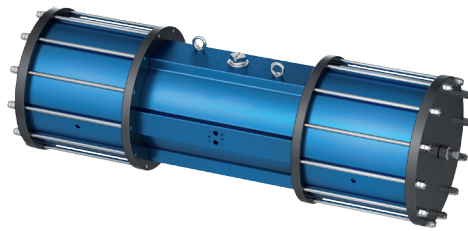

SADF-M 180°

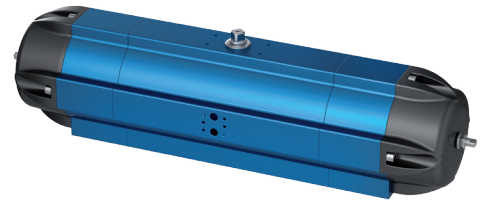

SAF 180°



SAD / SAF 90°



SADT / SADF 90°

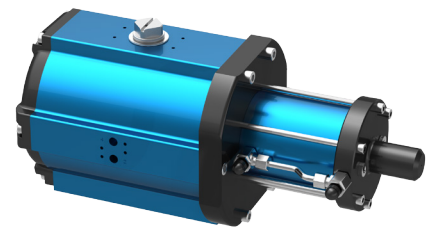

SAD / SAF-HD 90°

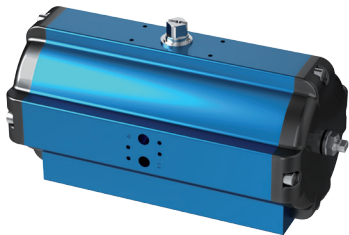

SAD 120° / 135° / 180°

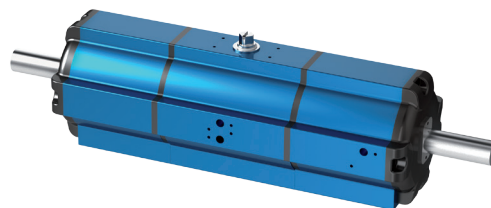

DAD / DAF 90°



SAD-M 180°

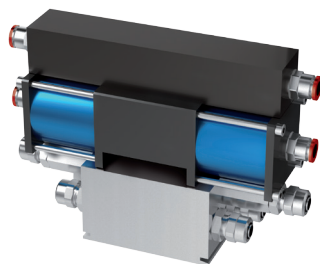

Flutorque (double pinion)

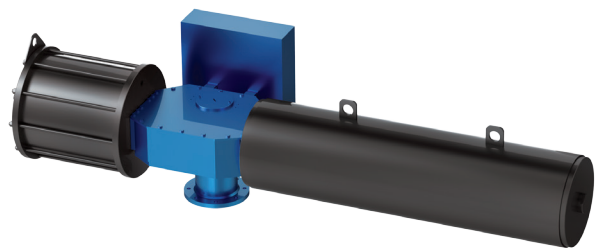

SPD / SPS



Pneumatic rotary actuators
made of stainless steel

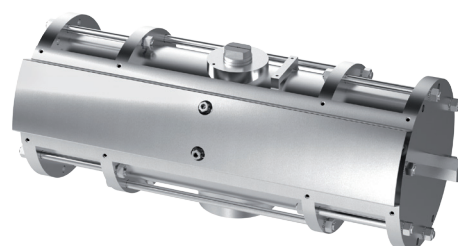

Pneumatic rotary actuators
made of stainless steel

LOCATION



AMG-PESCH GmbH
Adam-Riese-Straße 1
D - 50996 Köln
Tel.: +49 (0) 22 36 - 89 16 - 0
Fax: +49 (0) 22 36 - 89 16 - 56
info@amg-pesch.com
www.amg-pesch.com

AMG-PESCH®



An **ERIKS** Company

QUALITY IS OUR DRIVE